

## Design and Development of Transmission System for Solar Vehicle

Aditya B. Kale<sup>1</sup>, Jyoti M. Phate<sup>2</sup>, Ranjit V. Rajale<sup>3</sup>, Rahul K. Shrivastav<sup>4</sup>

<sup>1</sup>(Assistant Professor, Shri Chhatrapati Shivaji Maharaj College of Engineering, Nepti.)

<sup>2</sup>(Assistant Professor, Shri Chhatrapati Shivaji Maharaj College of Engineering, Nepti.)

**Abstract:** Transmission system is mechanisms which transmit the power develop by prime mover, often the term transmission refers simply to the differential gearbox that provide torque and speed variation. To design and develop transmission system, used Brushless DC motor as a driving source having capacity 2KW to get required speed 45km/hr. Motor get power from battery which charged with the use of solar panel. Selection of differential is done with required gear ratio to sufficient torque and velocity at output.

**Keywords:** BLDC motor, Differential Gearbox, Torque, Gear Ratio.

### I. Introduction

Now a day's solar energy is efficient not only to generate electricity but for automobiles also. Solar energy use to power the vehicles. Internal combustion engines release millions of ton of pollutants into environment each year. The use of solar energy compared to internal combustion is very much cheaper and mainly pollution free. The power converters and storage battery are been used to achieve required voltage for BLDC motor. This BLDC motor is select as per required torque. Designing of differential is heart of this search paper, which required many parameters like mass of vehicle, required gear ratio, torque etc. As per motor specification we choose a controller to control motor and indirectly the rpm.

### II. Problem Statement And Objective

To design, develop and fabricate the transmission system. We have to use BLDC motor having power less than 2kw and by using this motor, we required the speed of vehicle 45 km/hr. Also our vehicle should be weighted as low as possible

### III. BLDC Motor

When engineers are faced with the challenge of designing electrical equipment to perform mechanical tasks, they might think about how electrical signals get converted to energy. So actuators and motors are among the devices that convert electrical signals into motion. Motors exchange electrical energy to mechanical energy. The simplest type of motor is the brushed DC motor. In this type of motor, electrical current is passed through coils that are arranged within a fixed magnetic field. The current generates magnetic fields in the coils; this causes the coil assembly to rotate, as each coil is pushed away from the like pole and pulled toward the unlike pole of the fixed field. To maintain rotation, it is necessary to continually reverse the current—so that coil polarities will continually flip, causing the coils to continue “chasing” the unlike fixed poles. Power to the coils is supplied through fixed conductive brushes that make contact with a rotating commutator; it is the rotation of the commutator that causes the reversal of the current through the coils. The commutator and brushes are the key components distinguishing the brushed DC motor from other motor types. Figure 1 illustrates the general principle of the brushed motor. Fixed brushes supply electric energy to the rotating commutator. As the commutator rotates, it continually flips the direction of the current into the coils, reversing the coil polarities so that the coils maintain rightward rotation. The commutator rotates because it is attached to the rotor on which the coils are mounted. <sup>[6]</sup>

### IV. Solar Panel

The main part of our vehicle is the solar panel, on which our whole system is dependent as the charging of battery is to be done only and only by solar panel, so selecting this was a very crucial part, it was selected on basis of type, wattage requirement of battery, availability. We have then finally gone for two mono crystalline type of 330W / 24V panel which will charge the battery in calculated time given below in calculation in given below. Solar panels of Merlin company are used.

**Table No. 1: Selection of Solar Panel**

Power(W)	Length	Width	Height	Efficiency
310	2100	985	30	14.98
320	2100	985	30	15.42
330	2100	985	30	15.95

### V. Battery

The selection of battery was also an important part considering the safety and load of the vehicle. We had the option of selecting dry cell battery, but we have selected lead acid as it fulfils the requirement and also by the factors as availability and economical purposes. So four batteries of 12V/100A each were taken in series for making the voltage 48V of battery pack. Safety of driver was also taken from the battery as it is kept behind the firewall of vehicle. Excide Battery is used.

### VI. Controller

The controller was selected as per the power requirement of the motor to accelerate and decelerate. Selected controller was a 24 tube type compatible with motor considered, which will provide the power indirectly the (rpm)to the motor as per user requirement. Proper spacing is provided to the controller in the frame of the vehicle as it is considered a crucial and delicate part of the vehicle which is responsible for the acceleration of wheels.

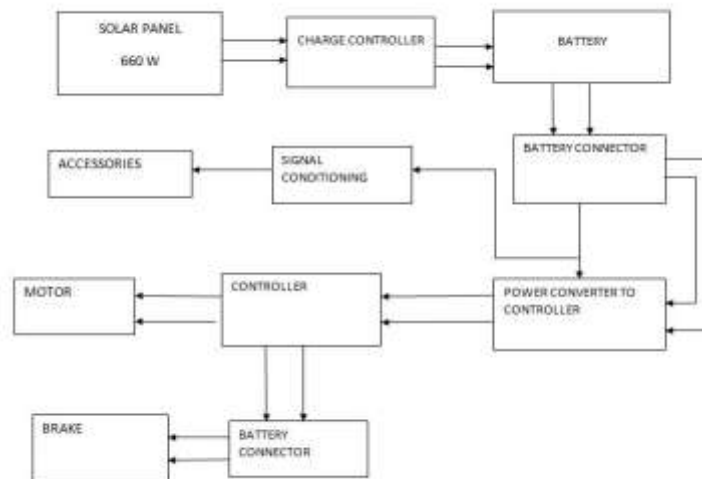

**Fig No. 1 Controller**

**Table No. 2 Selection of Controller**

Voltage (V)	Power (W)	Max limit (A)	Under voltage (V)	Brake handle (V)
48	850	84	41.5-0.5	1.2-4.3
48	1000	100	41.5-0.5	1.2-4.3

### VII. Circuit Layout of Car



**Figure No. 3 Circuit Layout of Car**

### VIII. Design Report

#### A. Torque Calculation

We assume following values

- Mass of vehicle = 310 kg
- Radius of wheel = 8inch = 0.203m
- Velocity = 45 km/hr = 12.5 m/s
- Coefficient of rolling resistance = 0.015
- Acceleration time = 5sec
- Acceleration required = 2.5m/s<sup>2</sup>
- Angle of inclination of road = 200
- Friction factor = 0.3
- Gross vehicle weight = 3041.1 N

1. Rolling resistance =  $(0.015+0.00016*V)*3041.1 = 51.698N$
  2. Acceleration force = mass \* acceleration = 775 N
  3. Grade resistance = Gross vehicle weight\*sinθ = 1040.11
  4. Total Tractive effort = Rolling resistance+ Acceleration force+ Grade resistance = 1866.81 N
  5. Torque required on wheel drive = Total Tractive effort\*Friction factor\*Radius of wheel= 113.68 Nm
  6. Motor Torque= (Wheel torque/Gear ratio)\*Transmission efficiency=27.89 Nm
- As per torque requirement we select the motor of 1000 W of 40 Nm torque and 3000 rpm

#### B. Selection of Gear Ratio for Differential

Torque available on wheel = Motor torque\*Gear ratio\*Transmission efficiency

$$V=\pi DN/60$$

**Table. 3.1:** Torque and Speed Available as per Gear Ratio

Available gear ratios	8:1	10:1	12:1
Torque Available on wheel	272Nm	340 Nm	408Nm

#### C. Selection of Wheels

$$V=\pi DN/60$$

$$9.388 = \pi * D * 588.01 / 60$$

$$D = 0.3049 \text{ mm} = 11.9 \text{ inch}$$

After studying transmission parameters like basic torque and angular velocity calculations we finalized the diameter of tires 12 inches.

### IX. Calculation of Vehicle

Mass of vehicle = 310 kg

Gear ratio = 10:1

Diameter of wheel = 12inch = 0.305m

1. Maximum velocity of vehicle =  $\pi DN/60 = 9.39 \text{ m/s} = 33.80 \text{ km/hr}$

2. Max Torque available at motor shaft = 40Nm

3. Acceleration

Rolling Resistance =  $(0.015+0.00016*V)*W = 50.18 \text{ N}$

Initial Effort = Max. Torque at rear wheel/Radius of wheel = 2229.5 N

Final Effort = Initial effort\*Transmission efficiency = 1895.08N

Acceleration =  $(\text{Final Effort}-\text{Rolling resistance}) / \text{mass of vehicle} = 5.9512 \text{ m/s}^2$

4. Gradability

$\theta = \sin^{-1}((\text{Final effort}-\text{rolling resistance})/\text{weight of vehicle}) = 37.11^\circ$

Gradability =  $\tan\theta * 100 = 76.31 \%$

### X. Conclusion

To reduce dependency of fossil solar vehicle is best solution. After examining the various components of transmission system, we came to the point that this transmission system provides power with the use of solar panel. The energy from solar panel is transferred towards the battery then the power is supplied to the BLDC motor .We use the differential connected with motor for the transmission system. Also we achieved with the use of tube controller which control the voltage or current in BLDC motor by controlling the speed. It has compact design also with simplicity in mechanism that provides simple maintenance whenever needed. After final testing we achieved 45km/hr speed of vehicle.

### **Acknowledgements**

We thank Prof.M.P.Nagarkar for assistance with design and developing the system. Also SCSMCOE Mechanical Engineering Staff for their comments that greatly improved the manuscript.

### **References**

#### **Journal Papers:**

- [1] Abhinya Chaturvedi, B. Kirti Kushwaha, Parul Kashyap, Dr. J. P. Navani, “ Solar Powered Vehicle,” Electrical & Electronics Department, Raj Kumar Goel Institute of Technology for Women, Ghaziabad, India, Vol. 3, Issue 2, pp: (270-273), Month: April - June 2015.
- [2] V.Naveen Prabhu and N.Manigandan, “Design and Fabrication of Solar Transport Vehicle,” IOSR Journal of Mechanical and Civil Engineering (IOSR-JMCE), e-ISSN: 2278-1684, p-ISSN: 2320-334X, PP 14-19.
- [3] R. Singh, M.Kumar, C.Malvi, “A Study and Design Based Simulation of Hybrid Solar Car,” IJETAE, ISSN 2250-2459, ISO 90001:2008, Volume 3, Issue 1, January 2013.
- [4] Verónica Flores Sánchez, Marco Osvaldo Viguera Zunigab, "Solar Vehicles Design For Urban Use: Case Adapted To Cuitláhuac Veracruz," 2013 ISES Solar World Congress, ScienceDirect Energy Procedia 57 ( 2014 ) 965 – 974.
- [5] Manu Jain and Sheldon S. Williamson, "Suitability Analysis of In-Wheel Motor Direct Drives for Electric and Hybrid Electric Vehicles", Power Electronics and Energy Research (PEER) Group Concordia University, Montreal, Canada.
- [6] R. Nicole, “Designing, Building of Solar Race Car for the World Solar Challenge (Phase 1)” Universal Journal of Mechanical Engineering3(4): 122-130, 2015.